

Features:

- 4 Watt typical P-1dB output Power at 1100~1250MHz
- Low noise figure, high gain with good gain flatness
- Low VSWR, unconditional stable
- SMA female connector I/O
- Single DC power supply, Integrated internal voltage regulator
- Operating temperature -40~+65°C, storage temperature -55~+125°C

Electrical Specifications

Parameters	Specifications		
	Minimum	Typical	Maximum
Frequency Range	1100 MHz		1250MHz
P-1dB Compression Point	+35 dBm	+36 dBm	
Output IP3	+45 dBm	+47 dBm	
Nominal SS Gain @25°C	27 dB	29dB	31 dB
Gain flatness		+/-0.5 dB	+/-0.75 dB
Gain Variation		+/-0.75 dB	
Noise Figure		3.0 dB	4.0 dB
Input VSWR		1.8:1	2.0:1
Output VSWR		1.7:1	1.9:1
Reverse Isolation	35 dB	40dB	
Spurious			-60 dBc
Operating Temperature	-40°C		+65°C
Survival Temperature	-55°C		+125°C
DC Voltage	+11.5V	+12 V	+13.0 V
DC Supply Current		800 mA	1100 mA
In/Out connectors	SMA female		
Outline Dimensions (not including SMA and feed pin)	Option 1 with heat sink: 2.28"x2.4"x1.45" Option 2 without heat sink 2.08"x1.08"x0.50"		

Functional Diagram

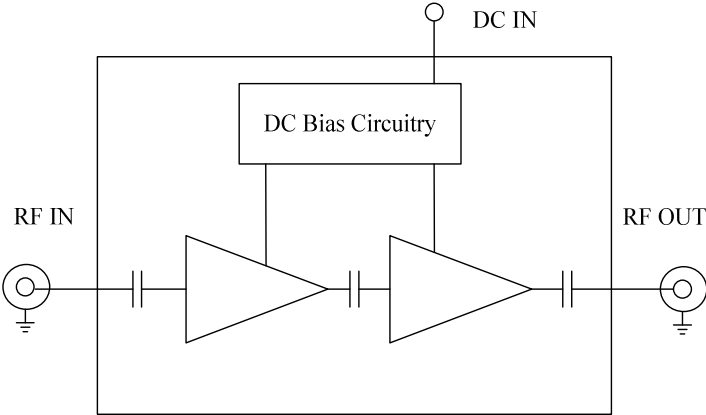

Mechanical Structure:

Option 1: outline drawing with heat sink

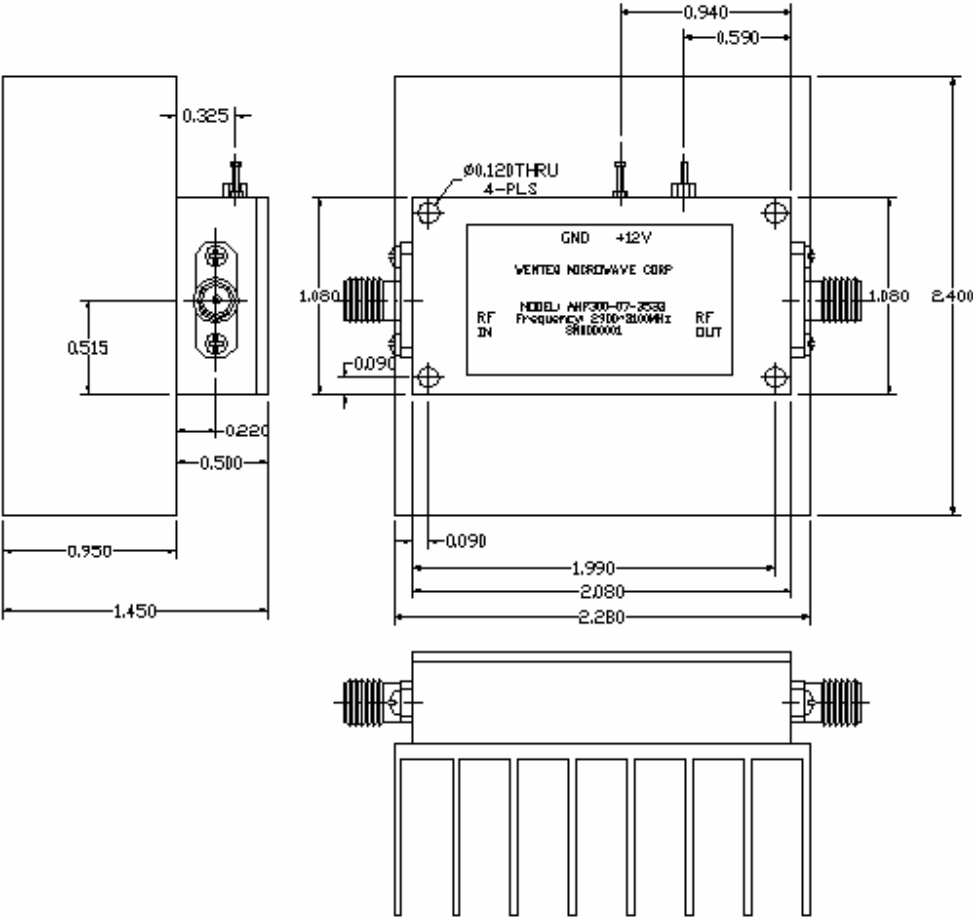

Note: All units in inches.

Option 2, outline drawing without heat sink

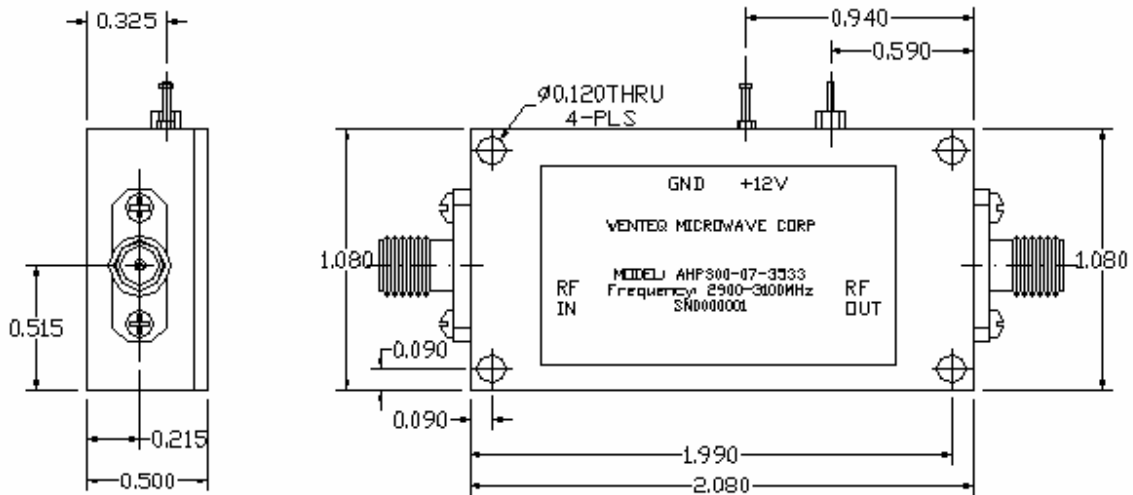

Note: All units in inches.

Absolute Maximum Ratings

DC Voltage	+13V
RF Input Power	+15dBm
Maximum Load VSWR	3:1
Storage Temperature	-55~+125°C
Operating Temperature	-45~+65°C