

Features:

- 6 Watt typical P-1dB output Power at 1850~1990MHz
- Low noise figure, high gain with good gain flatness
- Low VSWR, unconditional stable
- SMA female connector I/O
- Single DC power supply, Integrated internal voltage regulator
- Operating temperature -40~+65°C, storage temperature -55~+125°C

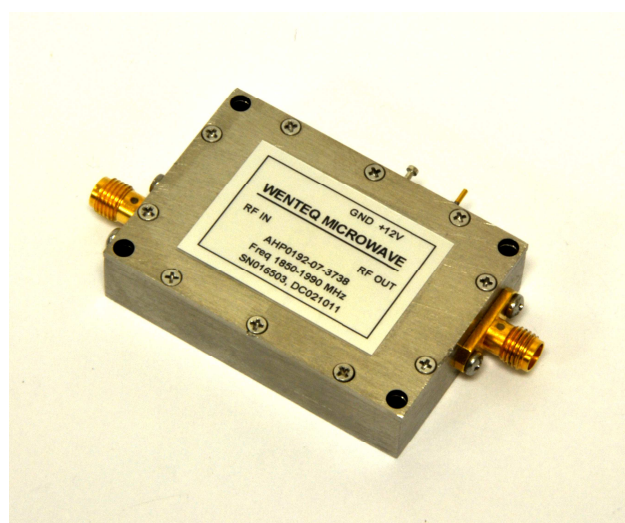

Electrical Specifications

Parameters	Specifications		
	Minimum	Typical	Maximum
Frequency Range	1850 MHz		1990MHz
P-1dB Compression Point	+37.5 dBm	+38.0 dBm	
Output IP3	+45 dBm	+50 dBm	
Nominal SS Gain @25°C	34 dB	37 dB	40 dB
Gain flatness over frequency		+/-1.0 dB	+/-1.25 dB
Gain Variation over temperature		+/-1.5 dB	+/-2.0 dB
Noise Figure		3.0 dB	4.0 dB
Input VSWR		1.5:1	1.8:1
Output VSWR		1.5:1	1.8:1
Reverse Isolation	45 dB	55dB	
Spurious			-60 dBc
Operating Temperature	-40°C		+65°C
Survival Temperature	-55°C		+125°C
DC Voltage	+11.5V	+12 V	+13.0 V
DC Supply Current		1800 mA	2100 mA
In/Out connectors	SMA female		
Outline Dimensions (not including SMA and feed pin)	2.08"x1.45"x0.50"		

Functional Diagram

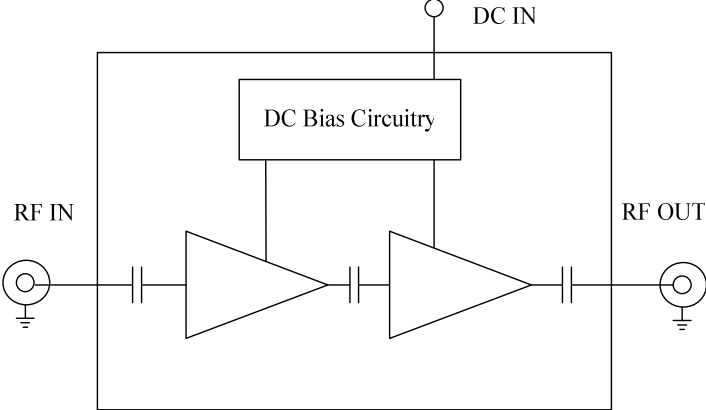

Mechanical Structure:

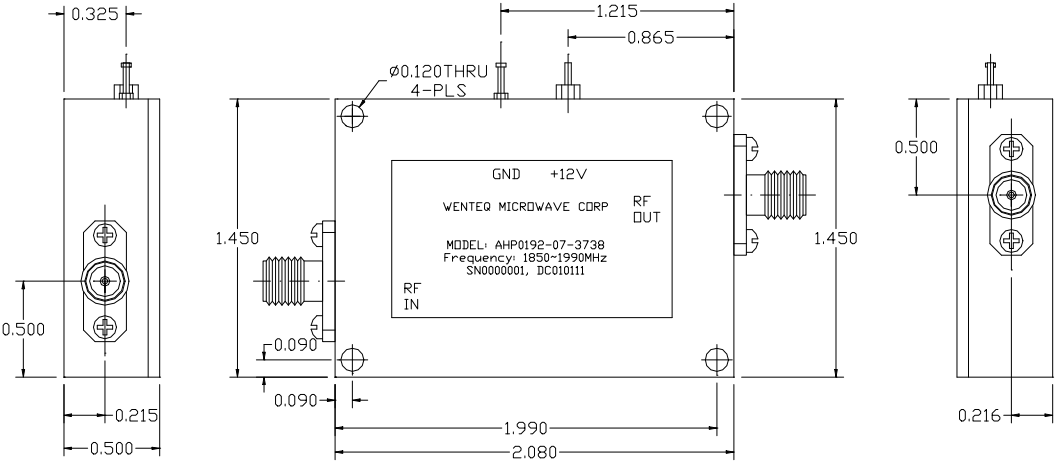

Note: All units in inches.

Absolute Maximum Ratings

DC Voltage	+13V
RF Input Power	+15dBm
Maximum Load VSWR	3:1
Storage Temperature	-55~+125°C
Operating Temperature	-45~+65°C

Note: External heat sink required for operation